

Laboratory 7 (drawn from lab text by Alciatore)

Transistor and Photoelectric Circuits

Required Components:

- 1x 330 Ω resistor
- 2x 1 k Ω resistors
- 1x 10k Ω resistor
- 1x 2N3904 small signal transistor
- 1x TIP31C power transistor
- 1x 1N4004 small-signal diode
- 1 Radio Shack 1.5-3V DC motor (RS part number: 273-223)
- 1x LED
- 1x photodiode/phototransistor pair (Newark part# 95B4823) or infrared diode/detector pair

Objectives

In this laboratory, you will study bipolar junction transistors (BJTs) and common photoelectric components. You will learn how to use light-emitting diodes (LEDs) as indicators, switch an inductive load with a power BJT, and use LED and phototransistor pairs as photo-interrupters. You will also learn how to bias a transistor and how to provide flyback protection with a diode.

Introduction

The following two pages provide information from the 2N3904 transistor data sheet. Data sheets provide pin-out information, where each pin is labeled with a function name and, if appropriate, a number. A data sheet also provides detailed electrical specifications that can help you properly design a circuit using the component.

Figure 1 illustrates the nomenclature used to describe the behavior of an npn bipolar transistor. It is a three terminal device consisting of the base, collector, and emitter. The transistor acts like a current valve by using the voltage bias across the base and emitter (V_{BE}) to control the flow of current in the collector-emitter circuit (I_c). The circuit connected to the collector and emitter along with the bias voltage dictate how much current flows.



October 2014



2N3904 / MMBT3904 / PZT3904 NPN General-Purpose Amplifier

Description

This device is designed as a general-purpose amplifier and switch. The useful dynamic range extends to 100 mA as a switch and to 100 MHz as an amplifier.

2N3904

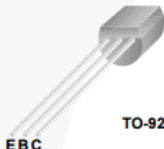

TO-92

EBC

MMBT3904

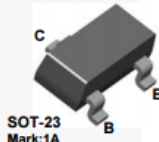

SOT-23
Mark:1A

C B E

PZT3904

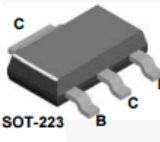

SOT-223

C B E

2N3904 / MMBT3904 / PZT3904 — NPN General-Purpose Amplifier

Absolute Maximum Ratings^{(1), (2)}

Stresses exceeding the absolute maximum ratings may damage the device. The device may not function or be operable above the recommended operating conditions and stressing the parts to these levels is not recommended. In addition, extended exposure to stresses above the recommended operating conditions may affect device reliability. The absolute maximum ratings are stress ratings only. Values are at $T_A = 25^\circ\text{C}$ unless otherwise noted.

Symbol	Parameter	Value	Unit
V_{CE0}	Collector-Emitter Voltage	40	V
V_{CBO}	Collector-Base Voltage	60	V
V_{EBO}	Emitter-Base Voltage	6.0	V
I_C	Collector Current - Continuous	200	mA
T_J, T_{STG}	Operating and Storage Junction Temperature Range	-55 to 150	$^\circ\text{C}$

Notes:

- These ratings are based on a maximum junction temperature of 150°C .
- These are steady-state limits. Fairchild Semiconductor should be consulted on applications involving pulsed or low-duty cycle operations.

Thermal Characteristics

Values are at $T_A = 25^\circ\text{C}$ unless otherwise noted.

Symbol	Parameter	Maximum			Unit
		2N3904	MMBT3904 ⁽³⁾	PZT3904 ⁽⁴⁾	
P_D	Total Device Dissipation	625	350	1,000	mW
	Derate Above 25°C	5.0	2.8	8.0	mW/ $^\circ\text{C}$
$R_{\theta JC}$	Thermal Resistance, Junction to Case	83.3			$^\circ\text{C}/\text{W}$
$R_{\theta JA}$	Thermal Resistance, Junction to Ambient	200	357	125	$^\circ\text{C}/\text{W}$

Notes:

- Device is mounted on FR-4 PCB 1.6 inch X 1.6 inch X 0.06 inch.
- Device is mounted on FR-4 PCB 36 mm X 18 mm X 1.5 mm, mounting pad for the collector lead minimum 6 cm^2 .

2N3904 / MMBT3904 / PZT3904 — NPN General-Purpose Amplifier

Electrical Characteristics

Values are at $T_A = 25^\circ\text{C}$ unless otherwise noted.

Symbol	Parameter	Conditions	Min.	Max.	Unit
OFF CHARACTERISTICS					
$V_{(BR)CEO}$	Collector-Emitter Breakdown Voltage	$I_C = 1.0\text{ mA}, I_B = 0$	40		V
$V_{(BR)CBO}$	Collector-Base Breakdown Voltage	$I_C = 10\ \mu\text{A}, I_E = 0$	60		V
$V_{(BR)EBO}$	Emitter-Base Breakdown Voltage	$I_E = 10\ \mu\text{A}, I_C = 0$	6.0		V
I_{BL}	Base Cut-Off Current	$V_{CE} = 30\text{ V}, V_{EB} = 3\text{ V}$		50	nA
I_{CEX}	Collector Cut-Off Current	$V_{CE} = 30\text{ V}, V_{EB} = 3\text{ V}$		50	nA
ON CHARACTERISTICS⁽⁵⁾					
h_{FE}	DC Current Gain	$I_C = 0.1\text{ mA}, V_{CE} = 1.0\text{ V}$	40		
		$I_C = 1.0\text{ mA}, V_{CE} = 1.0\text{ V}$	70		
		$I_C = 10\text{ mA}, V_{CE} = 1.0\text{ V}$	100	300	
		$I_C = 50\text{ mA}, V_{CE} = 1.0\text{ V}$	60		
		$I_C = 100\text{ mA}, V_{CE} = 1.0\text{ V}$	30		
$V_{CE(sat)}$	Collector-Emitter Saturation Voltage	$I_C = 10\text{ mA}, I_B = 1.0\text{ mA}$		0.2	V
		$I_C = 50\text{ mA}, I_B = 5.0\text{ mA}$		0.3	
$V_{BE(sat)}$	Base-Emitter Saturation Voltage	$I_C = 10\text{ mA}, I_B = 1.0\text{ mA}$	0.65	0.85	V
		$I_C = 50\text{ mA}, I_B = 5.0\text{ mA}$		0.95	
SMALL SIGNAL CHARACTERISTICS					
f_T	Current Gain - Bandwidth Product	$I_C = 10\text{ mA}, V_{CE} = 20\text{ V},$ $f = 100\text{ MHz}$	300		MHz
C_{obo}	Output Capacitance	$V_{CB} = 5.0\text{ V}, I_E = 0,$ $f = 100\text{ kHz}$		4.0	pF
C_{ibo}	Input Capacitance	$V_{EB} = 0.5\text{ V}, I_C = 0,$ $f = 100\text{ kHz}$		8.0	pF
NF	Noise Figure	$I_C = 100\ \mu\text{A}, V_{CE} = 5.0\text{ V},$ $R_S = 1.0\text{ k}\Omega,$ $f = 10\text{ Hz to }15.7\text{ kHz}$		5.0	dB
SWITCHING CHARACTERISTICS					
t_d	Delay Time	$V_{CC} = 3.0\text{ V}, V_{BE} = 0.5\text{ V}$ $I_C = 10\text{ mA}, I_{B1} = 1.0\text{ mA}$		35	ns
t_r	Rise Time			35	ns
t_s	Storage Time	$V_{CC} = 3.0\text{ V}, I_C = 10\text{ mA},$ $I_{B1} = I_{B2} = 1.0\text{ mA}$		200	ns
t_f	Fall Time			50	ns

Note:

5. Pulse test: pulse width $\leq 300\ \mu\text{s}$, duty cycle $\leq 2.0\%$.

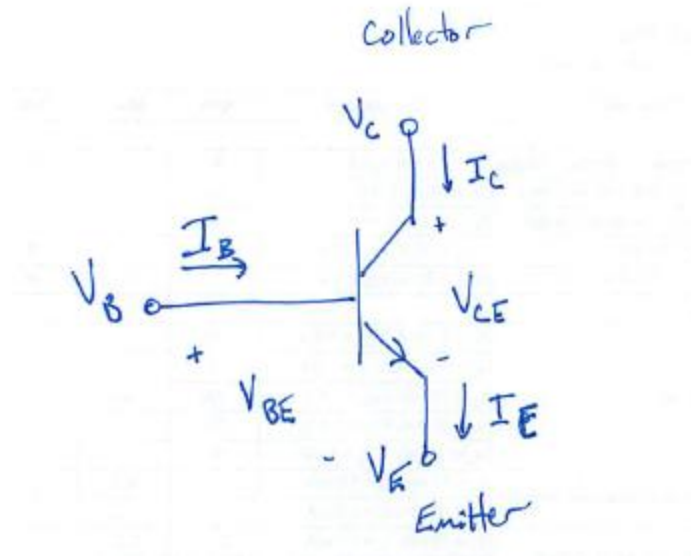

Figure 1: 1 npn bipolar transistor symbol and nomenclature.

Here are some general relationships between the variables shown in Figure 1:

$$V_{BE} = V_B - V_E \quad (1)$$

$$V_{CE} = V_C - V_E \quad (2)$$

$$I_E = I_B + I_C \quad (3)$$

Also, generally,

$$V_C > V_E \quad (4)$$

When the transistor is in saturation (i.e., fully ON),

$$V_{BE} \approx 0.6V \text{ to } 0.7V, \quad V_{CE} \approx 0.2V, \text{ and } I_C \gg I_B \quad (5)$$

and when the transistor is in its cutoff state,

$$V_{BE} < 0.6V \text{ and } I_C = I_B = I_E = 0 \quad (6)$$

In the cutoff state, the transistor does not conduct current.

Laboratory Procedure / Summary Sheet

Names: _____

1. Build the simple LED indicator circuit shown below (without the 2nd resistor). See Section 3.3.3 in textbook to identify the LED polarity. Gradually increase V_{in} from 0 V to 5 V and record V_{in} and measure V_D when you consider the LED to be on. Also **calculate** (don't measure) the current I_D based on the recorded voltages.

$V_{in} =$ _____

$V_D =$ _____

$I_D =$ _____

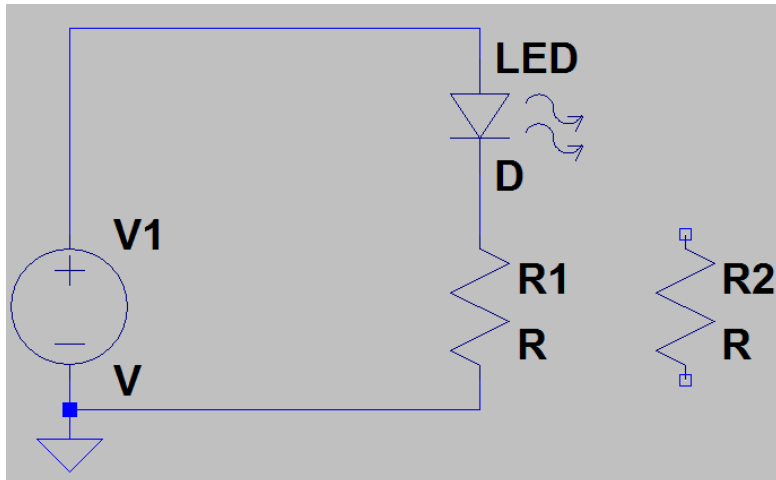

Figure 2 LED circuit.

2. Add the second resistor in parallel and repeat the same experiment looking for the V_{in} where you consider the LED to be on.

$V_{in} =$ _____

$V_D =$ _____

$I_D =$ _____

Explain what happens and why.

- Build a simple transistor switch (See figure below) using a 2N3904 small signal transistor and a base resistor (R_B) of $1\text{ k}\Omega$. Use one channel of the DC power supply with a voltage meter to supply V_{in} . Use another channel of the DC power supply for $V_2 = 10\text{V}$.

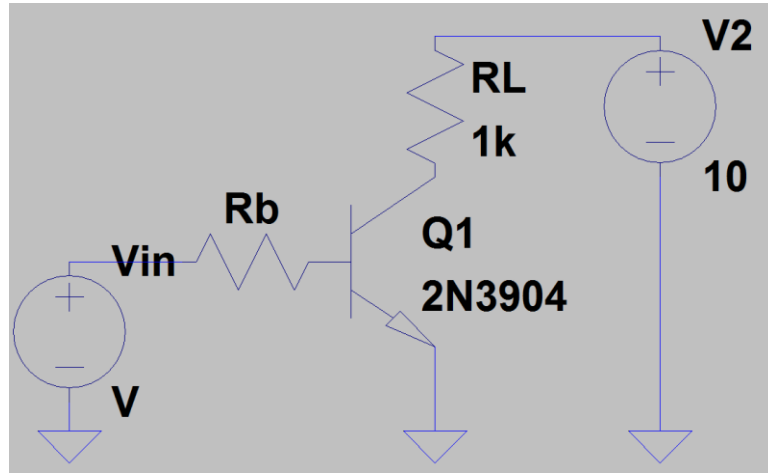

Figure 3 Transistor switch circuit.

Label the pins of the transistor in Fig. 3. Now use the 2N3904 datasheet provided to help you **draw and label the pins on Fig. 4** and to record the following values:

$I_{C(max)} =$ _____ $V_{CE(max)} =$ _____

$V_{BE(sat)} =$ _____

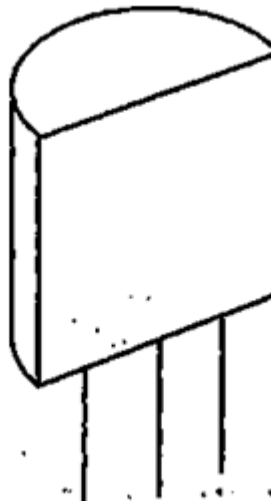

Figure 4 2N3904 pin-out.

Vary V_{in} as indicated in the table below and record the associated values for V_{BE} and V_{CE} . Use $R_B = 1\text{ k}\Omega$ for the base resistor.

Laboratory 7, Transistors and Photoelectric Circuits

V_{in}	V_{BE}	V_{CE}
0.0		
0.4		
0.5		
0.6		
0.7		
0.8		
0.9		
1.0		

Graph your data and describe your conclusions about when saturation occurs for the transistor.

Change the base resistor (R_B) to 10 k Ω and repeat the measurements.

V_{in}	V_{BE}	V_{CE}
0.0		
0.4		
0.5		
0.6		
0.7		
0.8		
0.9		
1.0		

Graph your data and explain what the effect of a larger base resistor is? Why is this so?

Laboratory 7, Transistors and Photoelectric Circuits

4. Build the circuit shown in Figure 5 with a TIP31C transistor (note the pinout shown in the right side of the diagram below) and a 1.5V-3V DC motor. The TIP31C transistor is required to provide adequate current to the motor. Be sure to use the flyback diode as shown. This diode provides protection to the transistor when control signal V_{in} is turned off. Flyback diodes are recommended when switching inductive loads such as motors and solenoids. The 1N4004 diode is well suited to this motor" since the motor current is well within the surge current capacity of the diode.

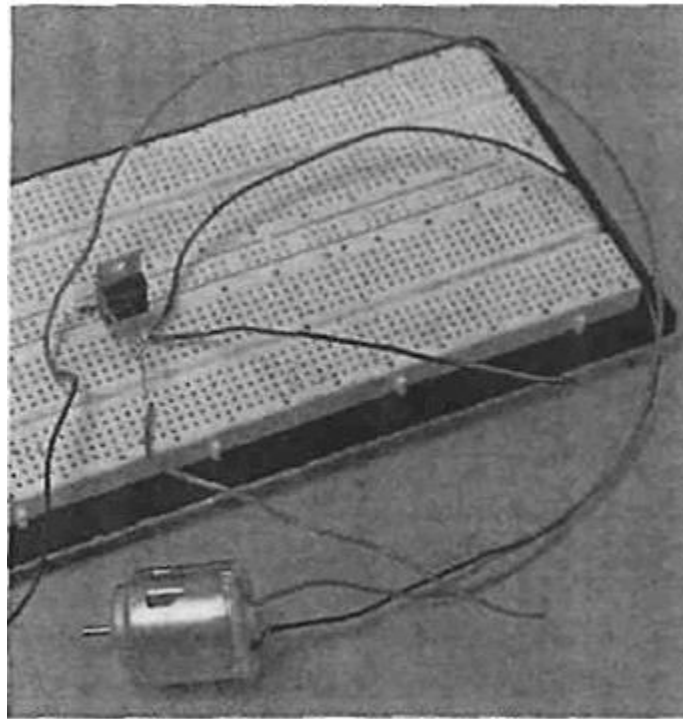
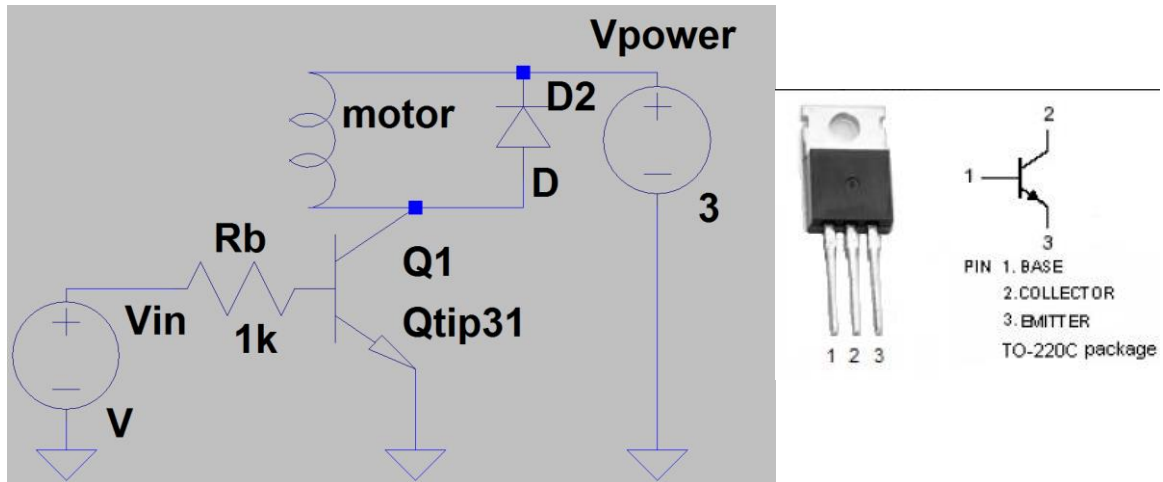

Figure 5 Motor and flyback diode.

Laboratory 7, Transistors and Photoelectric Circuits

Gradually increase V_{in} from 0 V to 10 V and describe what happens.

Apply a $5V_{pp}$, 2.5V DC offset (0 to 5V) square wave input to V_{in} . Start with a low frequency (e.g., 1 Hz) and then try some higher frequencies, increasing the frequency in 1 Hz increments up to 20 Hz and then 10 Hz increments up to 100 Hz. Describe what happens.

Explain how the flyback diode works.

Laboratory 7, Transistors and Photoelectric Circuits

- Examine the photo-interrupter and look at its specifications. Build the circuit shown in Figure 6, using the resistors indicated. Note that a single 5V source can be used to provide both voltage signals, and the ground for the input and output circuits must be connected to be common.

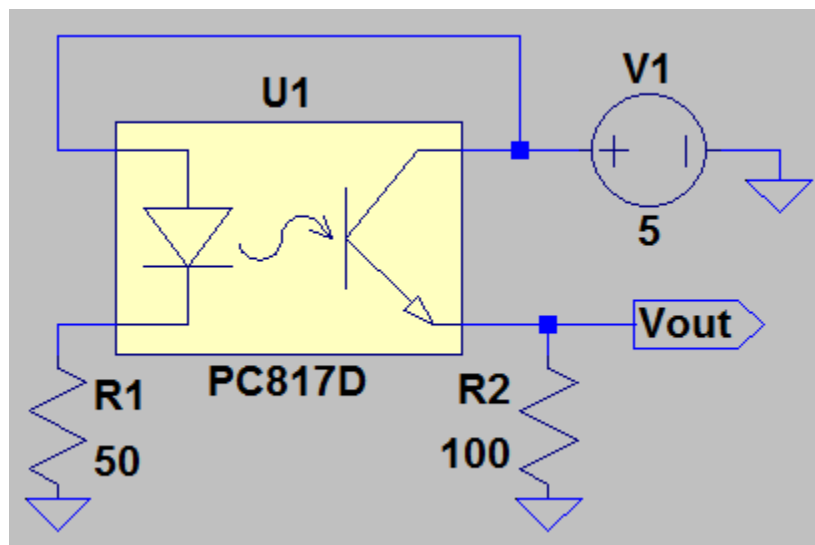
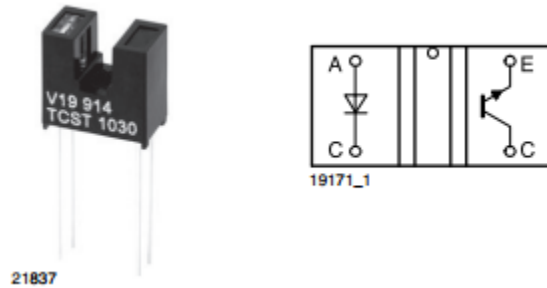

Figure 6 Photo-interrupter, the part number in the schematic is meaningless.

Measure the output voltage (V_{out}) with and without the beam interrupted (e.g., with a thick sheet of paper or a plastic card). What conditions (interrupted or not) correspond to the high and low states of the output? Explain why each condition results in the respective state.

Why are the resistors required?